



Development of a helium-cooled divertor concept: design-related requirements on materials and fabrication technology

P. Norajitra^{a,*}, L.V. Boccaccini^a, E. Diegele^a, V. Filatov^b, A. Gervash^b,
R. Giniyatulin^b, S. Gordeev^a, V. Heinzl^a, G. Janeschitz^a, J. Konys^a,
W. Krauss^a, R. Kruessmann^a, S. Malang^a, I. Mazul^b, A. Moeslang^a,
C. Petersen^a, G. Reimann^a, M. Rieth^a, G. Rizzi^a, M. Romyantsev^b,
R. Ruprecht^a, V. Slobodtchouk^a

^a *Forschungszentrum Karlsruhe, P.O. Box 3640, D-76021 Karlsruhe, Germany*

^b *D.V. Efremov Institute, Scientific Technical Centre, 'Sintez', 196641 St. Petersburg, Russia*

Abstract

Within the framework of the EU power plant conceptual study (PPCS), a modular He-cooled divertor concept with integrated pin array (HEMP) is being developed at the Forschungszentrum Karlsruhe. The design goal is to achieve a high heat flux of at least about 10–15 MW/m², which is proposed for a near-term reactor model like DEMO. The development and optimization of the divertor concept require a close link between the main issues: design, analyses, materials and fabrication technology, and experiments with feedbacks between them to be accounted for. Design-specific requirements on materials and fabrication issues will be discussed.

© 2004 Elsevier B.V. All rights reserved.

1. Introduction

The main function of the divertor is to remove the fusion reaction ash (α -particles), unburnt fuel, and eroded particles from the reactor, which adversely affect the quality of the plasma. As one of the high-heat-flux components of the fusion reactor, the divertor has to resist a high surface heat load of up to 15 MW/m² depending on the reactor type and physics. About 15% of the total fusion thermal power have to be removed by the divertor. In addition, it serves as a shield for the magnetic coils behind it. Helium-cooled divertor concepts are regarded suitable for use in fusion power plants for safety reasons, as they enable the use of a coolant compatible with any blanket concept, since water would

not be acceptable e.g. in connection with ceramic breeder blankets using large amounts of beryllium. Moreover, they allow for a relatively high gas outlet temperature, and, hence, a high thermal efficiency of the power conversion systems.

Developing a divertor concept for the demonstration reactor DEMO which will presumably start its operation approx in 2038 is associated with many factors of uncertainty, such as the physical boundary conditions and the properties of the candidate materials envisaged for the divertor concept. Many materials properties are subject to physical limitations, by which the ranges of application of the materials are limited. To extend the ranges of application and increase serviceability of the material, materials development is required. Many design requirements therefore depend on future achievements and can only be extrapolated from the present stage of knowledge. The development and optimization of the divertor concept require a close link and an iterative approach between the main issues of design,

* Corresponding author. Tel.: +49-7247 82 3673; fax: +49-7247 82 7673.

E-mail address: prachai.norajitra@imf.fzk.de (P. Norajitra).

analyses, materials, fabrication technology, and experiments. The proposed HEMP concept is based on the foregoing studies [1,2]. For the first design and layout of this divertor concept the PPCS reactor model C [3] is used as a basis.

2. Design criteria and design requirements for the divertor

General objectives and criteria for the design are: (a) resisting a peak heat flux of at least 10 MW/m^2 , (b) a modular design instead of large plate structures is required to reduce the thermal stresses, (c) keeping the divertor operating temperature window at the lower boundary higher than the ductile–brittle transition temperature (DBTT) limit and at the upper boundary lower than the recrystallization temperature (RCT) limit of the structural components made of refractory alloys under irradiation, (d) the divertor has to survive a certain number of thermal cycles ($n \approx 100\text{--}1000$) between operating temperature and room temperature during operation.

To meet the design criteria above, the following design features have to be accounted for: (a) transport of the cooling agent as closely as possible to the target plates in order to maintain the maximum structure temperature as low as possible, (b) short heat conduction paths from the plasma-facing side to the cooled surface to maintain the maximum structure temperature below the RCT limit, supported by (c) achieving high heat transfer coefficients while keeping the coolant mass flow rate and, thus, the pressure loss as well as the pumping power as low as possible, and (d) joint constructions between the divertor components that fulfill the functions of withstanding the thermocyclic loadings and stopping the crack growth introduced from the plasma-facing side to maintain the integrity of the structures beneath it.

3. Description of the HEMP design

The divertor is divided into cassettes (Fig. 1) [4] for easier handling and maintenance. It is essentially composed of the thermally highly loaded target plates, the dome that contains the opening for removing the particles by vacuum pumps, and the main structure or bulk which houses the manifolds for the coolant. A part of the cross section of the proposed HEMP divertor modules with all dimensions of interest is shown in Fig. 2 (left). The numbers in brackets below refer to this figure. Details of the thimble are shown on the right hand side. The HEMP concept employs small tiles made of tungsten (1) as thermal shield which is brazed to a finger-like (thimble) structure (2) made of tungsten alloy W-1% La_2O_3 (WL10). The tungsten tiles are designed

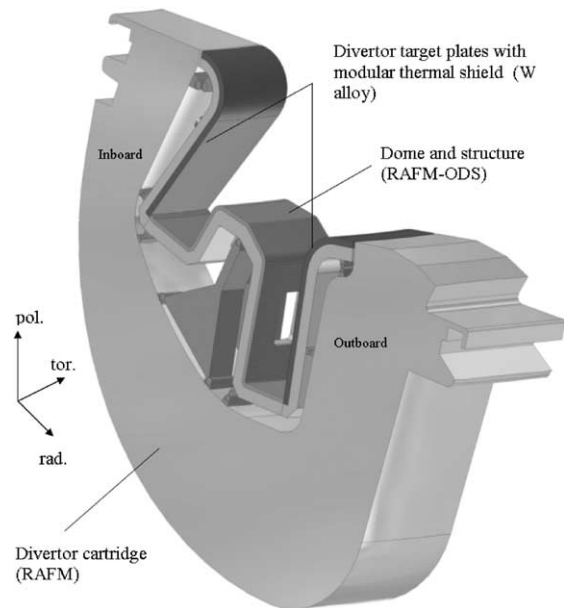

Fig. 1. Principle design of a 7.5° divertor cassette.

separately from the thimble for safety reasons to stop the crack growth at the joining surface. In the first design, these modules have a nominal width of 16 mm. In detail, the W tiles are of quadratic shape with an area of $15.8 \times 15.8 \text{ mm}^2$ and 5 mm thick, whereas the thimbles are of cylindrical shape with an outer diameter of 14 mm and a wall thickness of 1 mm. A pin array as heat transfer promoter (3) is integrated at the bottom of the thimble by means of brazing to enhance the cooling surface and, hence, to increase the heat transfer capacity. The pin array (or slot array as alternative, Fig. 3) is made from tungsten or tungsten alloy. The thimble (2) and the flow promoter panel (3) can be manufactured together in a piece, if a suitable processing method is available. In this case, the brazing joint between them can be omitted. The finger units containing the parts (1), (2), and (3) are fixed to the front plate of the supporting structure made from the oxide dispersion-strengthened (ODS) reduced-activation (RAFM) ferritic–martensitic steel EUROFER (transition zone T) by means of brazing. The front plate is connected to the back plate by parallel walls forming a stiff structure. All supporting structures and manifold units are made of ODS EUROFER.

The divertor is cooled with high-pressure helium at 10 MPa, which is supplied by an inlet manifold (4). It enters the finger unit at a temperature of about 600°C and flows upwards to the pin array at the outer wall. After the 90° bend, it flows radially from the outer edge through the pin array towards the center with high velocity leading to a relatively high heat transfer coefficient of about $65 \text{ kW/m}^2 \text{ K}$ related to the surface area of

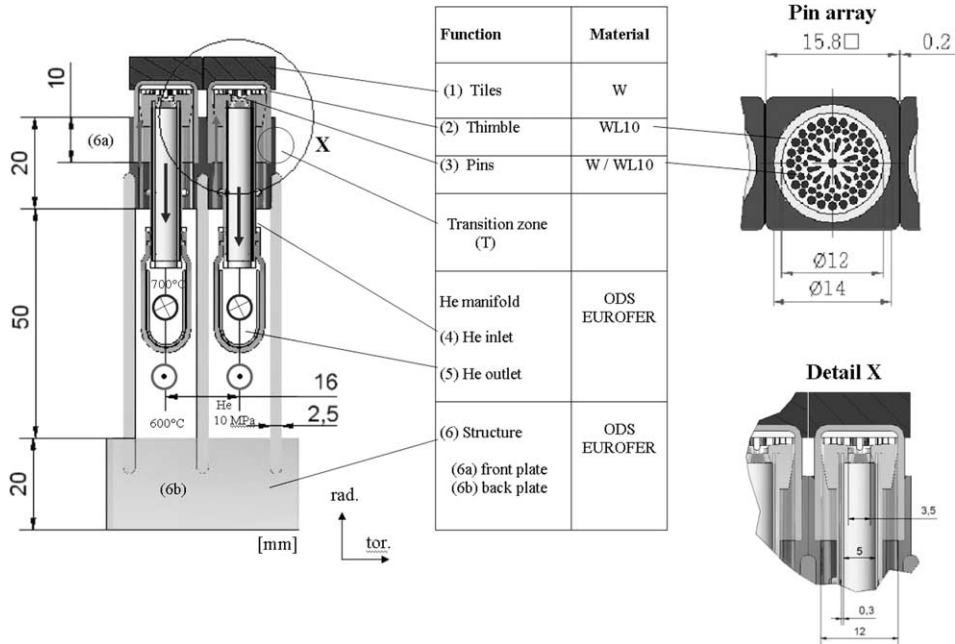

Fig. 2. The FZK modular divertor concept with integrated pin array (HEMP).

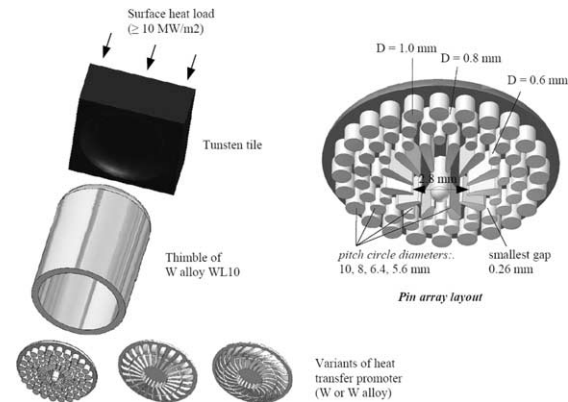

Fig. 3. Cooling unit with various kinds of heat transfer promoter.

the basis plate [4], is heated up to about 700 °C, and routed via an outlet tube downwards to the He outlet manifold (5). The direction of flow may also be reversed (see detail investigation in Ref. [5]). The optimization of the pin or slot arrangement with respect to size, shape, and distance is an important thermohydraulic issue.

The large mismatch in thermal expansion coefficients of W alloys and the steel structure, which are about $4-6 \times 10^{-6}/K$ and $10-14 \times 10^{-6}/K$, respectively, will locally cause very high plastic strains at edges and corners in the transition zone (T) under temperature cyclic loadings. To avoid thermocyclic plastification at the joints, an appropriate design of transition pieces using mechanical

interlocks, like screws or bayonet fixings, is now under investigation. A further step of the design is the optimization of the module size in order to achieve as low a number of modules as possible and, thus, to minimize the production costs (current number of modules approx 300 000).

4. Design-related requirements on materials

4.1. Tungsten tile

Background: Tungsten is considered the most promising material that can withstand the specified high heat load, because it possesses a high melting point, high thermal conductivity, and relatively low thermal expansion. In addition, it is low-activating, has a high resistance against sputtering and erosion, and suitable for the use as thermal shield. Its disadvantages are poor DBTT and RCT values, high hardness, and a high brittleness, which make the fabrication of tungsten components comparatively difficult. The tiles have no structural function. A sacrificial layer of 2 mm is foreseen for an estimated service life of about 1–2 years.

Requirements: High resistance of material against peak heat load and sputtering energy.

4.2. Thimble of tungsten alloy

Background: The operating temperature window of the W alloys structures is restricted by the DBTT at the

lower and the RCT at the upper boundary. Generally, the DBTT, RCT, and strength properties of W and/or W alloys are determined by the deformation processes and their prehistory as well as by the doping compositions. For irradiated W alloys the presently known temperature window range extends from 800 to 1200 °C (see also Ref. [6]).

Tungsten can be alloyed with other refractory elements (e.g. Hf, Ta, Mo, Nb) and noble metals (e.g. Re, Ir, Rh). W-Re alloy, for instance, exhibits excellent DBTT and RCT behaviors in the unirradiated condition and good mechanical properties. Drawbacks in application include its strongly reduced thermal conductivity, its small resources, and its activation. The RCT of W can be improved by adding fine oxide particles (ODS tungsten), such as ThO₂, La₂O₃ or Y₂O₃. In detail, the W precursors are blended with oxides and subjected to sintering and mechanical processing to achieve high densities.

Requirements: A development of W alloys to broaden this operating temperature window from the today's range of 800–1200 °C to 600–1300 °C, i.e. increasing the RCT and simultaneously lowering the DBTT.

Note: It is assumed that finer grains or ODS particles will positively affect the properties, as it is known from the use of SPD (severe plastic deformation) techniques e.g. in the fabrication of very thin foils or wires. State of the art of the material knowledge is given in detail in Ref. [7].

5. Design-related requirements on fabrication methods

5.1. Fabrication of the heat transfer promoters from W/W alloy

Background: Standard tooling methods (e.g. milling) are not applicable for these materials due to their high hardness and toughness. In particular, this holds for parts with microstructure shapes and relatively high aspect ratios (i.e. the ratio between the height and width of the structure).

Requirements: (a) Development of a fabrication method for mass production ($n > 300\,000$) of divertor components from W or W alloy: Heat transfer promoters like pin or slot arrays, thimbles, and tiles, (b) development of a fabrication and assembly technology, and testing methods for the divertor supporting structures of ODS RAFM steel, including manifold and pipe system of the same material.

5.2. Joining of tile/thimble (W/W) and structural parts (W/steel)

Background: Welding is not applicable due to the problems concerning grain growth and other micro-

structural changes of the W and ODS alloys during joining. High-temperature brazing and diffusion bonding are considered alternative methods.

Requirements: (a) The joint between tile and thimble should exhibit a sufficient ductility for successfully stopping the crack growth, (b) for the joint between structures with internal pressure loadings mechanical interlocks like screws or bayonet fixings have to be foreseen, (c) leak tests and temperature cyclic tests have to be carried out. State of the art of the fabrication technology is given in detail in Ref. [7].

6. Conclusions and outlook

In this paper, the design of a He-cooled divertor concept is described. It meets a large variety of requirements imposed by e.g. loading conditions and materials and fabrication issues. Design-related requirements on materials and fabrication technology are pointed out.

The divertor design will be further investigated. Development of materials and fabrication methods will be continued, tests with different fabrication methods will be performed. Thermohydraulic performance will be assessed by means of different commercial CFD tools which will be compared with each other. Thermomechanical calculations are also under way. First results of heat transfer experiments are expected to be obtained within the last quarter of 2003. In addition, a large helium loop is planned to be constructed at the EFRE-MOV Institute in St. Petersburg, Russia. An electronic beam facility is available there, which allows for the simulation of a high heat load of at least 10 MW/m². Planning and specification of the experiment programmes are under way. The loop is scheduled to be in operation in 2005.

Acknowledgements

This work has been performed within the framework of the Nuclear Fusion Program of Forschungszentrum Karlsruhe and is supported by the European Union within the European Fusion Technology Program.

References

- [1] S. Hermsmeyer, S. Malang, in: Proceedings of ISFNT-6, San Diego, 2002.
- [2] E. Diegele, R. Krüssmann, S. Malang, P. Norajitra, G. Rizzi, in: 22nd Symposium on Fusion Technology, Helsinki, Finland, September 2002.
- [3] P. Norajitra et al., Conceptual design of the dual-coolant blanket within the framework of the EU power plant conceptual study, FZKA 6780, May 2003.

- [4] P. Norajitra, et al., in: 20th Symposium on Fusion Engineering (SOFE), San Diego, CA, USA, 13–17 October 2003.
- [5] R. Kruessmann, et al., in: 20th Symposium on Fusion Engineering (SOFE), San Diego, CA, USA, 13–17 October 2003.
- [6] S.J. Zinkle, N.M. Ghoniem, *Fusion Eng. and Des.* 51&52 (2000) 55.
- [7] W. Krauss, J. Konys, P. Norajitra, V. Filatov, in: 11th International Conference on Fusion Reactor Materials (ICFRM-11), Kyoto, Japan, 7–12 December 2003.